

GFM-C Series

GFM-1000C 2V1000Ah

GFM-C series VRLA battery uses latest AGM technology, high purity raw materials and many patented technologies that ensure its long floating and cycle life, it is applicable to less frequency of power failure, and shallow discharge of depth site. It is mainly used for indoor telecommunication base station.



Benefits

- Long life according to EUROBAT Classification
- High discharge performance
- 99%+ gas recombination efficiency
- Maximum charge efficiency
- Low self-discharge rate
- Horizontal installization

Applications

- Telecommunications
- Power system
- UPS
- Emergency power

Standards

- IEC 60896-21/22
- JIS C8704-1/2
- EUROBAT guide

Drawing

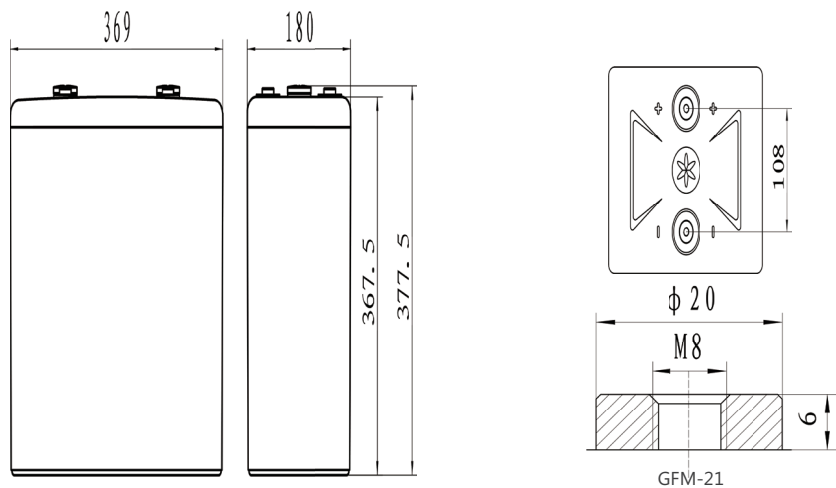

Specifications

Battery Model	GFM-1000C			
Design Life (years, 25°C)	15			
Capacity (Ah, 25°C)	10HR (100A, 1.80V)	5HR (170A, 1.80V)	3HR (250A, 1.80V)	1HR (550A, 1.75V)
	1000	850	750	550
Dimensions (mm)	Length	Width	Height	Total Height
	369	180	367.5	377.5
Approx. Weight (kg)	58.5			
Reference Internal Resistance (mΩ)	0.38(fully charged @ 25°C)			
Maximum Discharge Current (A/5 Sec.)	3500			
Self-Discharge (25°C)	≤ 1.5% per months			
Charge Voltage (V/cell, 25°C)	Cycle use		Float use	
	2.35 (-3.5mV/°C/cell), max charge current: 150A		2.25 (-3.5mV/°C/cell)	
Short Circuit Current (A)	8600			

Discharge Data

Constant Current Discharge Data (25°C, A)															
End Voltage (V/cell)	min							h							
	5	10	15	20	30	40	50	1	1.5	2	3	5	8	10	24
1.60	1520	1400	1310	1180	960	880	750	680	532	392	290	198	136	110	48.4
1.65	1420	1310	1220	1100	890	800	700	640	490	376	280	190	132	108	47.6
1.70	1290	1180	1080	1000	820	730	660	600	456	360	270	182	128	106	46.8
1.75	1170	1040	940	860	750	670	600	550	420	340	260	176	124	103	45.4
1.80	1000	920	840	780	680	610	550	500	392	320	250	170	120	100	44.2

Constant Power Discharge Data (25°C, W/cell)															
End Voltage (V/cell)	min							h							
	5	10	15	20	30	40	50	1	1.5	2	3	5	8	10	24
1.60	2606	2427	2288	2070	1695	1562	1336	1217	958	711	531	367	255	207	92.8
1.65	2486	2319	2174	1969	1603	1448	1272	1167	897	695	521	357	251	206	92.2
1.70	2306	2131	1962	1824	1506	1347	1223	1115	853	677	512	348	247	204	91.6
1.75	2133	1915	1741	1599	1403	1260	1132	1040	798	650	500	341	242	201	89.4
1.80	1852	1720	1579	1472	1291	1162	1051	958	753	618	486	332	235	197	87.5

Rack Layout

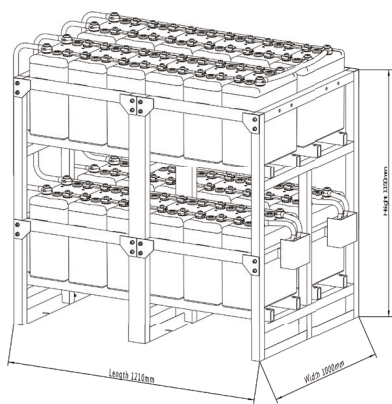

48V Standard Rack (Anti-seismic rack is optional)
 Rack material: powder-coated steel
 Height*width: 2*2
 Ref. GFM-1000C Rack (approx. weight: 1585kg)

Performance Curve

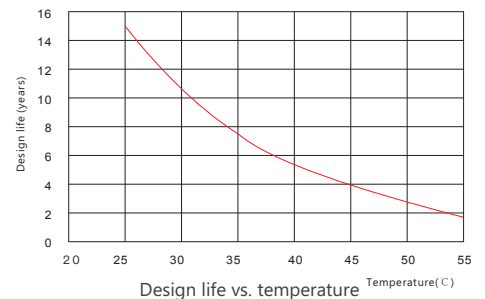
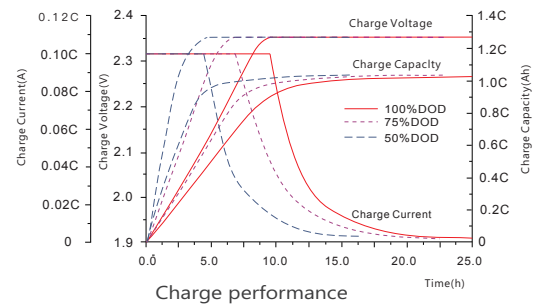
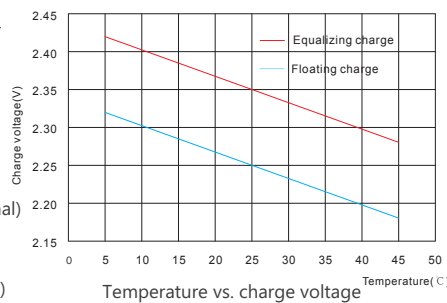
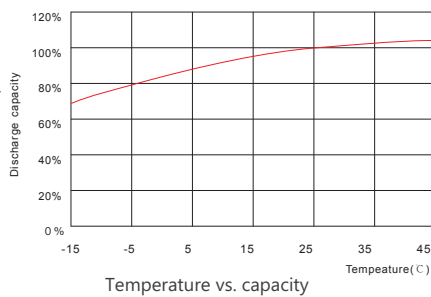

Sacred Sun Power Sources Co., Ltd.

No.1 Shengyang Road Qufu City, PRC
 sales@sacredsun.cn

Sacred Sun Asia Pacific

No. 15, Yishun Industrial Street 1,
 #01-17, WIN5, Singapore 768091
 sales.asia@sacredsun.cn

Sacred Sun Europe SPRL

Schoenstraat 96-9140 Temse, Belgium
 sales.eu@sacredsun.cn

Sacred Sun MEA FZE

S10122A1019 Jebel Ali, Dubai,
 United Arab Emirates
 sales.mea@sacredsun.cn